EK-RRD40-OM-001

RRD40 Optical Disc Drive

Owner's Manual

digitalTM

EK-RRD40-OM-001

RRD40 Optical Disc Drive

Owner's Manual

Prepared by Educational Services
of Digital Equipment Corporation

September 1988

Copyright ©1988 by Digital Equipment Corporation.

All Rights Reserved.
Printed in U.S.A.

CLASS 1
LASER PRODUCT

DANGER
INVISIBLE LASER RADIATION WHEN OPEN.
AVOID DIRECT EXPOSURE TO BEAM.

WARNING

Use of controls and adjustments or performance of procedures other than those specified herein may result in hazardous radiation exposure.

NOTICE: This equipment generates, uses, and may emit radio frequency energy. The equipment has been type tested and found to comply with the limits for a Class A computing device pursuant to Subpart J of Part 15 of FCC Rules, which are designed to provide reasonable protection against such radio frequency interference when operated in a commercial environment. Operation of this equipment in a residential area may cause interference in which case the user at his own expense may be required to take measures to correct the interference.

The information in this document is subject to change without notice and should not be construed as a commitment by Digital Equipment Corporation.

Digital Equipment Corporation assumes no responsibility for any errors that may appear in this document.

The software, if any, described in this document is furnished under a license and may be used or copied only in accordance with the terms of such license. No responsibility is assumed for the use or reliability of software or equipment that is not supplied by Digital Equipment Corporation or its affiliated companies.

The following are trademarks of Digital Equipment Corporation:

 ™	DECservice	MicroVAX	Q22-Bus	VAX
DEC	DECsystem-10	MicroVAX II	Rainbow	VAXstation
DECmailer	DECSYSTEM-20	MicroVAX 3000	RRD50	VAXstation II
DECmate	DECUS	PDP	RSTS	VMS
DECnet	DECwriter	P/OS	RSX	VT
	DIBOL	Professional	RT	Work Processor
	MASSBUS	Q-Bus	UNIBUS	

Contents

1 Introduction

1.1	Scope	1-1
1.2	Product Variations	1-1
1.2.1	Drives	1-2
1.2.2	Interfaces	1-3
1.3	Specifications	1-4

2 Installation

2.1	Half-Height RRD40 Installation	2-1
2.1.1	Assigning a SCSI Address ID Number	2-2
2.1.2	Cabling the Half-Height RRD40	2-4
2.1.3	Testing the Half-Height RRD40	2-4
2.2	Tabletop RRD40 Installation	2-4
2.2.1	Equipment	2-4
2.2.2	Voltage Selecting	2-6
2.2.3	Cabling the Tabletop RRD40	2-6
2.2.4	Installing the Power Cord/Verifying Power	2-10
2.2.5	Assigning an Address ID/Unit Number	2-10
2.2.6	Testing the Tabletop RRD40	2-11

3 Operation

3.1	Front Panel	3-1
3.2	Loading a Disc	3-2
3.3	Unloading a Disc	3-3
3.4	Disc and Caddy Repairing	3-5
3.4.1	Removing the Disc from the Caddy	3-6
3.4.2	Cleaning a Disc	3-9
3.4.3	Replacing the Disc in the Caddy	3-9

4 Testing the RRD40 on a MicroVAX

4.1	Running Tests on MicroVAX Host Systems	4-1
4.2	Customer Run Tests on a MicroVAX Host System	4-2
4.2.1	Equipment	4-2
4.2.2	Running MDM: Customer Mode	4-2
4.3	Service Mode Testing on a MicroVAX Host System	4-7
4.3.1	Equipment	4-7
4.3.2	Running MDM: Menu/Command Line Mode	4-7
4.3.3	Help	4-8
4.3.4	Tests	4-9
4.3.5	Running the Tests	4-9
4.3.6	Error Reports	4-13

A Digital Repair Services

Figures

1-1	RRD40 Tabletop Drive	1-2
1-2	RRD40 Half-Height Drive	1-3
2-1	SCSI Controller	2-2
2-2	RRD40 Rear Panels	2-5
2-3	Cabling: Q-Bus Interface	2-7
2-4	Cabling: 1 RRD40 with SCSI Interface	2-8
2-5	Cabling: 2 RRD40s with SCSI Interface	2-9
3-1	RRD40 Front Panel	3-2
3-2	Disc Loading	3-4
3-3	Caddy Parts	3-5
3-4	Disc Tabs	3-6
3-5	Separating the Caddy	3-7
3-6	Separating the Disc and Housing	3-8

Tables

1-1	RRD40 Specifications	1-4
2-1	SCSI Address ID Number Settings	2-3
2-2	Tabletop RRD40 Installation: Parts List	2-5
4-1	Verify Mode Functional Tests	4-5
4-2	Service Mode Functional Tests	4-6
4-3	Utilities	4-6
4-4	Diagnostic Monitor: Set/Show Commands	4-11
4-5	Drive Error Codes (Service Mode Only)	4-14
4-6	Controller Error Codes (Service Mode Only)	4-15

1.1 Scope

This manual is for the user and operator of the RRD40 Optical Disc Drive. The RRD40 is a read-only storage device that reads data stored on removable optical discs. An optical disc is 4.7 inches in diameter and can store 600 megabytes (about 600 million characters) of data.

In optical storage devices, data (which is stored on the disc) is read off of the disc by a laser system. A laser is a concentrated beam of light. In the RRD40, the laser (contained in the RRD40 disc drive) shines light on the disc. The intensity of the light reflected back (to the laser from the disc) determines the data on the disc. The concentrated beam of light from the laser is so fine that it is possible to store massive amounts of data on a single disc.

1.2 Product Variations

There are two RRD40 drives that use one of two interfaces.

1.2.1 Drives

The RRD40 is available as a tabletop version or a "half-height" version. The half-height version is designed to be embedded into an existing host system enclosure. Figure 1-1 and Figure 1-2 show the two RRD40 drives. Although the two are physically different, they are functionally the same.

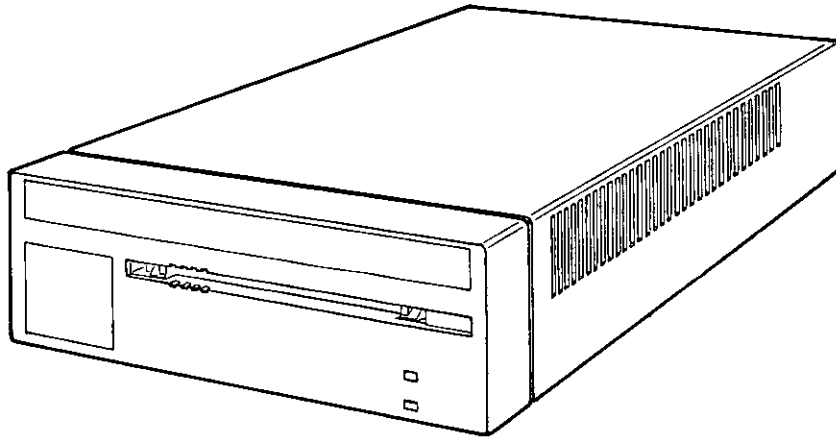

SHR-0138-88

Figure 1-1 RRD40 Tabletop Drive

1.3 Specifications

Table 1-1 gives the specifications of the RRD40 Disc Drive.

Table 1-1 RRD40 Specifications

PHYSICAL		
	TABLETOP	HALF-HEIGHT
Height:	76.2 mm (3.0 in)	41.5 mm (1.6 in)
Width:	229 mm (9.125 in)	146 mm (5.75 in)
Depth:	280 mm (11.0 in)	209 mm (8.07 in)
Weight:	4 kg (8.8 lb)	2 kg (4.4 lb)
PERFORMANCE		
Capacity Per Disc:	635 megabytes	
Average Latency:	155 msec at outer track 60 msec at inner track	
Average Transfer Rate:	175.2 Kbytes per second	
Initialization Startup Time:	Less than 6 seconds	
ENVIRONMENTAL		
	OPERATING	NON-OPERATING
Ambient Temperature:	10 to 50°C 50 to 122°F	-40 to 70°C 40 to 158°F
Relative Humidity:	10 to 80%	5 to 95%
Maximum Wet Bulb:	28°C (78°F)	46°C (115°F)
Max Pressure Altitude:	3.4 km	13.6 km
Heat Dissipation:	14 W (typical)	

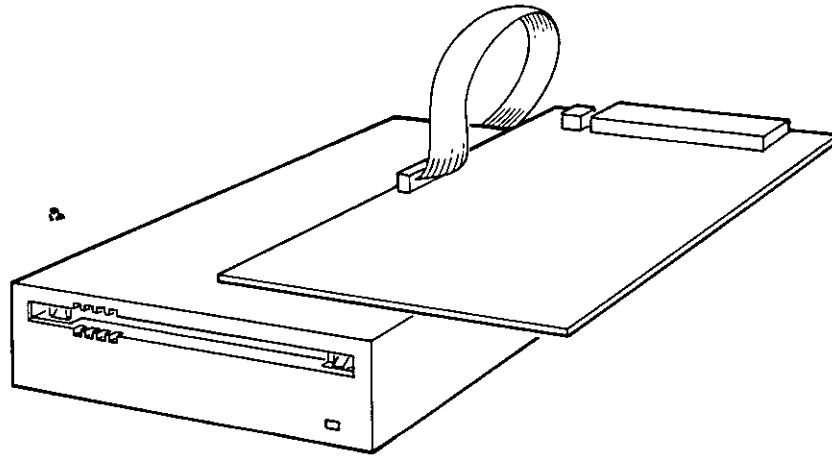

SHR-0148-88

Figure 1-2 RRD40 Half-Height Drive

1.2.2 Interfaces

The RRD40 has two possible interfaces: Q-Bus and SCSI.

An RRD40 with a Q-Bus interface uses the M7552 controller module as the interface to the host system. The Q-Bus interface is used in only the tabletop version of the RRD40 drive.

An RRD40 with the SCSI interface uses a SCSI controller module as the interface to the host system. The SCSI controller connects to the SCSI adapter in the host system and functions as a SCSI device on the host system. An RRD40 with the SCSI interface is available for both the Tabletop and Half-Height RRD40 drives.

This chapter gives instructions on how to install the RRD40 Disc Drive. Most of the instructions deal with the installation of the Tabletop RRD40; the installation of the Half-Height RRD40 is covered briefly.

2.1 Half-Height RRD40 Installation

The Half-Height RRD40 comes with a SCSI interface only. This version of the drive is generally not customer installable. This section gives some general installation information, but refer to the host system documentation for specific installation instructions.

The installation of the Half-Height RRD40 into the host system unit is dependent on the system enclosure and also the current configuration of the host system.

If you are installing a Tabletop RRD40, go to Section 2.2.

2.1.1 Assigning a SCSI Address ID Number

Locate the switch pack on the SCSI controller module (refer to Figure 2-1). The switch pack can be assigned any number 0-7. The four DIP switches on the switch pack are numbered 1-4. Switch 1 sets the most significant bit, and switch 3 sets the least significant bit. Switch 4 is unused. The board comes preset to ID number 0 (all switches down).

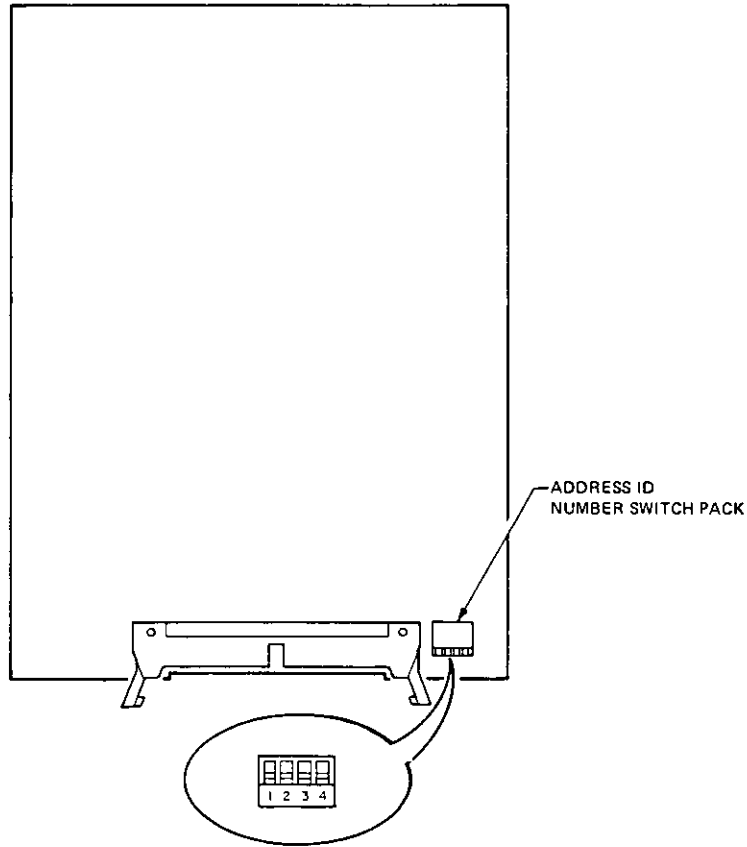

SHR-0149-88

Figure 2-1 SCSI Controller

Proceed as follows:

1. Determine the SCSI Address ID number that your RRD40 will be assigned. This number is based on the current configuration of the host system and can be any number 0-7. Refer to your host system documentation for more information on the SCSI Address ID numbers.
2. Set the switch pack to the correct ID number. Table 2-1 gives the settings for each of the eight possible ID numbers that the controller can be assigned. Use a ball point pen or pointed object to set the switches. **NEVER USE A PENCIL TO SET THE SWITCH PACK.** The graphite used in pencils can damage the switch pack.

Table 2-1 SCSI Address ID Number Settings

ID Number	Binary Code	Switch Settings			
		1	2	3	4
0	000	0	0	0	0
1	001	0	0	1	0
2	010	0	1	0	0
3	011	0	1	1	0
4	100	1	0	0	0
5	101	1	0	1	0
6	110	1	1	0	0
7	111	1	1	1	0

Key to Switch Settings

0 = ON = UP
 1 = OFF = DOWN
 Switch 4 must be set to 0

2.1.2 Cabling the Half-Height RRD40

The Half-Height RRD40 is embedded inside the host system enclosure and is cabled internally. Refer to the host system documentation.

2.1.3 Testing the Half-Height RRD40

The Half-Height RRD40 uses a SCSI interface and responds to the same testing as the other SCSI devices on the host system. Refer to the host system documentation.

2.2 Tabletop RRD40 Installation

The Tabletop RRD40 comes with either a Q-Bus or SCSI interface. The RRD40 rear panels are different for each interface, but the installation procedures are similar. Figure 2-2 shows both rear panels.

The RRD40 with the Q-Bus interface has only one cable connector on the rear panel. The RRD40 with the SCSI interface has two cable connectors on the rear panel. There are two cable connectors because SCSI RRD40's can be "daisy-chained" together. Refer to Section 2.2.3 for more information on the cable connectors.

2.2.1 Equipment

The equipment necessary to install the Tabletop RRD40 depends on which interface (SCSI or Q-Bus) your RRD40 uses. Table 2-2 lists the parts needed for each installation. Make sure that you have all parts necessary for installation before proceeding.

Note that if your RRD40 uses the Q-Bus interface, the M7552 controller module should have already been installed into the host system by a specially trained Digital Field Service Engineer.

Q-BUS INTERFACE

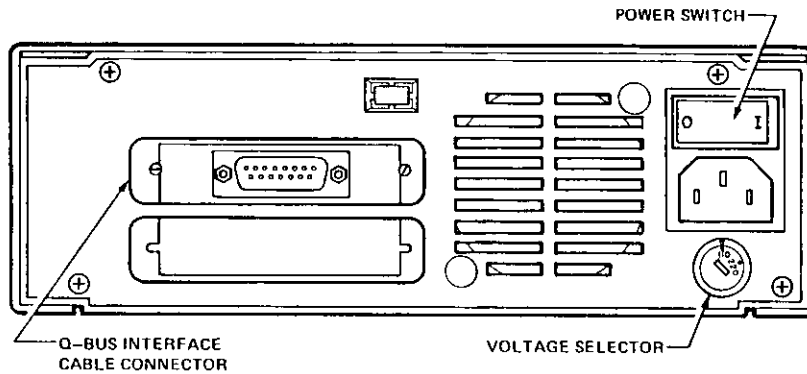

SCSI INTERFACE

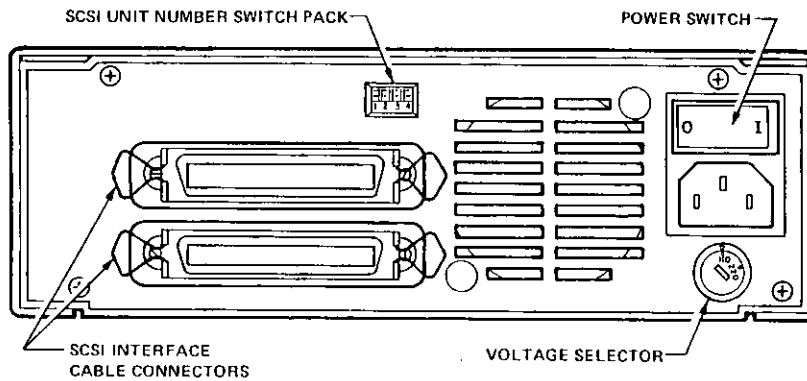

Figure 2-2 RRD40 Rear Panels

Table 2-2 Tabletop RRD40 Installation: Parts List

Equipment	Part Number	SCSI Interface	Q-Bus Interface
External I/O Cable	BC18R-XX	-	✓
	or	-	✓
	BC16V-XX	-	✓
	17-02007-01	✓	-
Power Cord	n/a	✓	✓
Test Disc	23507-03	✓	✓
M7552 Controller Kit	KRQ50-xx	-	✓

2.2.2 Voltage Selecting

The rear panel of the RRD40 contains a voltage selector that can be set to one of two voltages (110 V or 220 V). Figure 2-2 shows the location of the selector on the rear panel. **Verify that the voltage that your RRD40 is set to is the correct voltage for your power requirements before powering up the drive.**

To change the setting of the voltage selector, insert a flat object (such as a screwdriver) into the selector and turn so the desired voltage is facing up. In Figure 2-2, the selected voltage is 110 V.

2.2.3 Cabling the Tabletop RRD40

The cabling is different depending on which interface your RRD40 uses. The Q-Bus interface is a simple connection from the rear of the drive to the host system. The SCSI interface requires a terminator assembly.

Q-Bus Interface

The cabling for the Q-Bus interface depends on the host system.

Some host systems (such as the MicroVAX 3000 series) have a cable connected directly to the controller module in the host system. This cable comes out of the rear of the host system and must be installed into the interface connector on the rear of the RRD40 drive. The cable is tightened onto the connector by hand. The rear panel of the RRD40 drive is shown in Figure 2-2.

Other host systems (such as the MicroVAX II) have an RRD40 bulkhead on the rear patch panel of the system. This bulkhead has two connectors marked "A" and "B". If this is the first RRD40 to be attached to the controller, then you would attach the cable to the "A" connector. The cable is tightened onto the connector by hand at both ends. Connect the cable to the host system first, and then to the rear of the RRD40 drive. The cabling is shown in Figure 2-3.

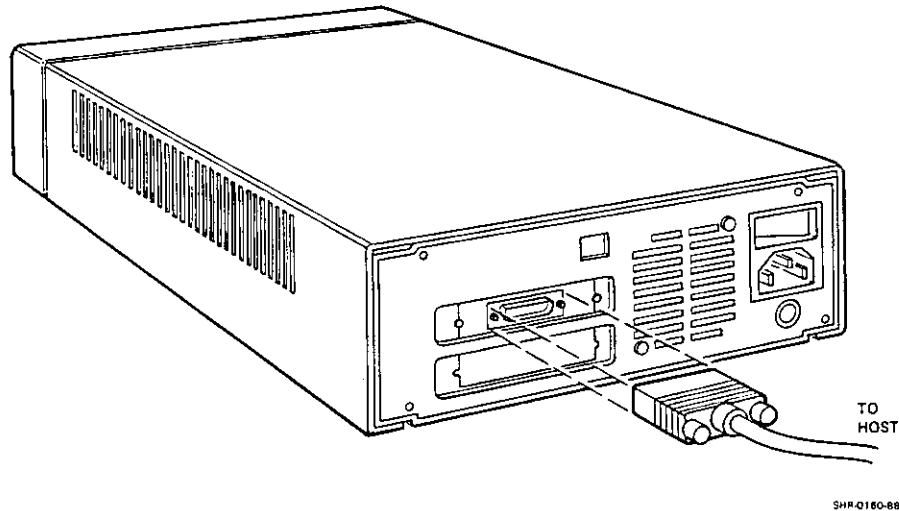

Figure 2-3 Cabling: Q-Bus Interface

SCSI Interface

An RRD40 which uses the SCSI interface has two cable connectors on the rear panel (shown in Figure 2-2). The SCSI interface allows for connecting multiple drives in a daisy-chain configuration. Because of this option, the final drive in the chain must be "terminated". The terminator is simply a connector for the unused rear panel interface connector on the drive. It is the same as the connector on the I/O cable.

If you have only one drive, the external I/O cable is connected from the host system to the top connector on the RRD40 drive. The terminator is then installed in the bottom connector on the rear panel of the drive.

If you have a second RRD40 drive, the external I/O cable for drive #2 goes from the bottom connector of drive #1 to the top connector of drive #2. The terminator is then installed into the bottom connector on the rear panel of drive #2.

Follow the applicable instructions.

Single drive cabling To cable a single drive, proceed as follows (refer to Figure 2-4):

1. Connect the external I/O cable to the SCSI port on the rear of the host system.
2. Connect the other end of the cable to the top connector on the rear of the drive.
3. Install a terminator assembly into the unused (bottom) connector on the rear of the RRD40.

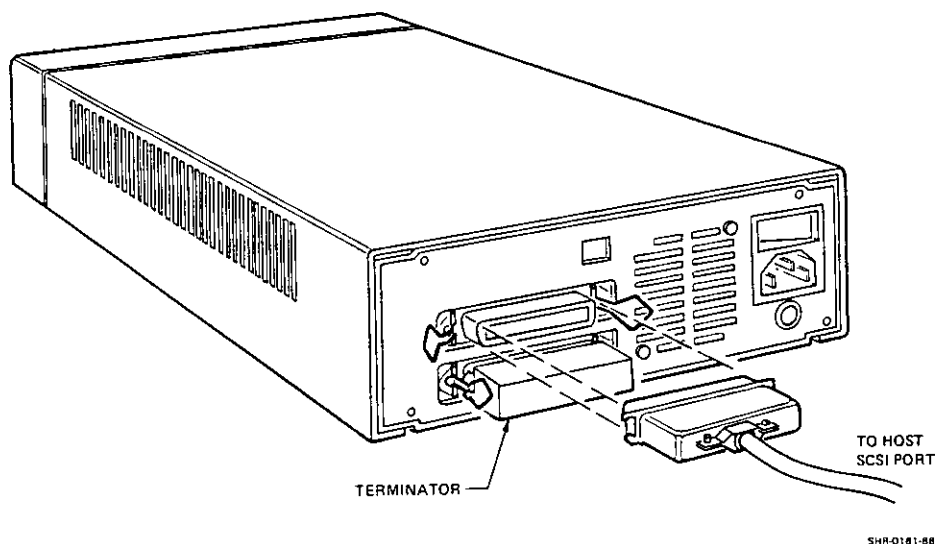

Figure 2-4 Cabling: 1 RRD40 with SCSI Interface

SHR-0181-88

Multiple drive cabling If you already have an RRD40 drive on the system, and you want to add another RRD40, then a "daisy-chain" cabling configuration is used. To daisy-chain a drive is to connect the new drive to the RRD40 that is already connected to the host system.

To daisy-chain a new drive to a previously connected drive, proceed as follows (refer to Figure 2-5):

1. Remove the terminator from the bottom connector of the RRD40 that is already connected to the host system.
2. Take the external I/O cable for the RRD40 drive that you are installing. Install one end into the open connector (the connector that you just removed the terminator from).
3. Install the other end of the I/O cable into the top connector of the "new" RRD40 (the drive that you are installing).
4. Install the terminator into the unused (bottom) interface connector on the RRD40 you are installing.

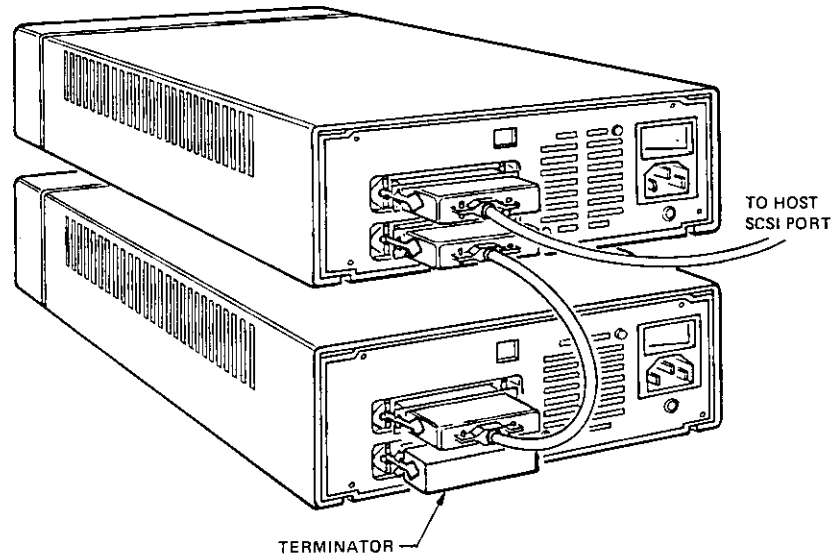

SHR-0162-88

Figure 2-5 Cabling: 2 RRD40s with SCSI Interface

2.2.4 Installing the Power Cord/Verifying Power

1. Make sure that the power switch on the rear panel of the RRD40 is set to the OFF (0) position (refer to Figure 2-2).
2. Install the female end of the power cord into the receptacle on the rear of the drive.
3. Install the other end of the power cord into a wall outlet rated for the correct voltage. Make sure the voltage selector is properly set.
4. Turn the rear panel power switch to the ON (1) position and verify that the POWER indicator on the front panel lights.

If the POWER indicator does not light, then a problem exists. Set the POWER switch back to the OFF (0) position. Verify that the wall outlet has power, and try again. If the indicator still fails to light, contact your Digital Service Representative before proceeding any further.

2.2.5 Assigning an Address ID/Unit Number

For the SCSI interface, you must assign the drive a SCSI Address ID number. For the Q-Bus interface, you must assign the drive a unit number. Follow the instructions that apply.

SCSI Interface

Locate the switch pack on the rear of the SCSI Tabletop RRD40 (shown in Figure 2-2). This switch pack sets the SCSI Address ID number that the RRD40 will respond to in the host system. The drive must be given a SCSI Address ID number by setting the switch pack. The four DIP switches on the switch pack are numbered 1-4. Switch 1 sets the most significant bit, and switch 3 sets the least significant bit. Switch 4 is unused. The board comes preset to Address ID number 0 (all switches down).

Proceed as follows:

1. Power down the drive.
2. Determine the SCSI Address ID number that your RRD40 will be assigned. This number is based on the current configuration of the host system and can be any number 0-7. Refer to your host system documentation for more information on the SCSI Address ID numbers.

3. Set the switch pack to the correct Address ID number. Table 2-1 gives the settings for each of the eight possible numbers that the controller can be assigned. Use a ball point pen or pointed object to set the switches. **NEVER USE A PENCIL TO SET THE SWITCH PACK.** The graphite used in pencils can damage the switch pack.
4. Verify power again by following step 4 in Section 2.2.4.

Q-Bus Interface

For the Q-Bus interface, the unit number is set through the MicroVAX Diagnostic Monitor (MDM). Instructions for running MDM are given in Chapter 4. The RRD40 drive comes preset to unit number 0. If you are assigning the RRD40 drive unit number 0, you need not run the Utility. If you want to set the RRD40 to a unit number other than unit number 0, proceed as follows.

1. Refer to Chapter 4 and load the MicroVAX Diagnostic Monitor.
2. At the Main Menu (shown in Section 4.2), select **Option #3: Display System Utilities Menu**. This will put you into the Utility that sets the unit number.
3. Follow the step by step instructions to set the unit number.
4. Return to the Main Menu and exit out of MDM by selecting **Option #5**.

2.2.6 Testing the Tabletop RRD40

The Tabletop RRD40 that uses a SCSI interface responds to the same testing as the other SCSI devices on the host system. Refer to the host system documentation.

The Tabletop RRD40 that uses the Q-Bus interface is tested through the MicroVAX Diagnostic Monitor (MDM). Refer to Chapter 4 for instructions on running RRD40 tests through MDM.

3-2 Operation

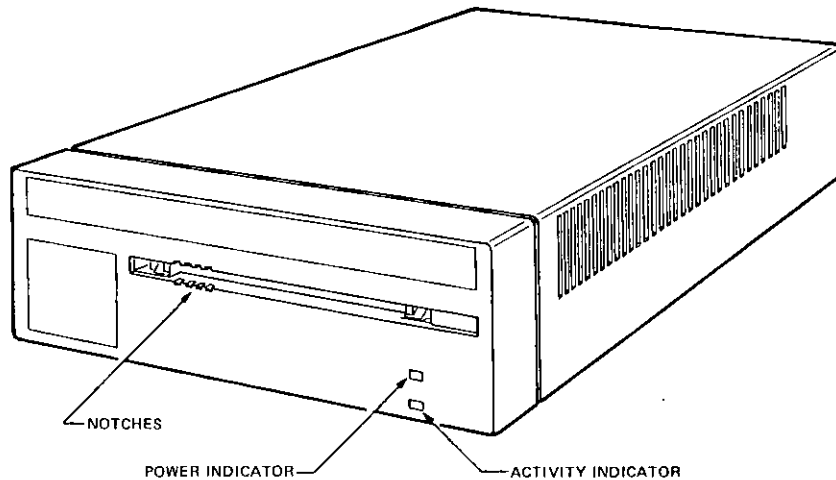

SHR-0163 88

Figure 3-1 RRD40 Front Panel

3.2 Loading a Disc

When loading a disc, the entire disc caddy is inserted into the disc opening on the front of the drive. **DO NOT** remove the disc from the caddy! Proceed as follows:

1. Make sure the power is on. On the Tabletop RRD40, this is indicated by the front panel POWER indicator being lit. On the Half-Height RRD40, make sure that the host system power is on.

It is important that power has been applied to the RRD40 drive before you load a disc.

2. Note that the disc is housed inside a protective caddy. Examine the disc caddy. Make sure that it is not cracked or damaged in any way. **NEVER LOAD A DAMAGED CADDY INTO AN RRD40 DRIVE!**

There are two variations of the RRD40: Tabletop and Half-Height (shown in Figure 1-1 and Figure 1-2). The Tabletop RRD40 connects to the host system via an external I/O cable. The Half-Height RRD40 is installed in the host system box and is connected internally. **Operating the drive is the same whether you have the Tabletop or Half-Height version.**

3.1 Front Panel

The front panel consists of a disc opening and one or two status indicators. The Tabletop RRD40 contains a POWER indicator and an ACTIVITY indicator (shown in Figure 3-1). The Half-Height RRD40 contains only the ACTIVITY indicator. There is no POWER indicator on the Half-Height drive because there is no power switch.

The POWER indicator on the Tabletop RRD40 lights when power is applied to the RRD40 (via the rear panel POWER switch). Refer to Chapter 2 for descriptions and illustrations of the rear panel.

The ACTIVITY indicator (present on both versions) lights solid when a disc is correctly loaded into the RRD40 drive. When an RRD40 disc is transferring data, the ACTIVITY indicator flashes.

3. Examine the disc inside the caddy. **DO NOT REMOVE THE DISC FROM THE CADDY.** Note that one side of the disc is labeled. The label should always be facing up as you insert the disc into the drive. When the label is facing up, the four notches on the disc housing will be on the left, as shown in Figure 3-2. These notches line up with four similar notches on the front of the RRD40, as shown in Figure 3-1.

NOTE: If you have the disc positioned label side up and the notches are on the right, then the disc is oriented incorrectly in the caddy. Do not proceed any further with the disc loading. Go to Section 3.4 on disc and caddy repairing.

4. Insert the disc caddy as shown in Figure 3-2. Make sure the notches on the left side of the disc caddy line up with the notches on the disc opening on the front of the drive. Slide the caddy in as far as it will go.
5. Remove the caddy. When removed, you will notice that the disc and its housing remain in the drive. Only the transparent sleeve comes out.
6. Check that the front panel **ACTIVITY** indicator lights solid within five seconds.

If the drive accepted the disc but the **ACTIVITY** indicator does not light, then the disc may have been oriented in the caddy incorrectly. Unload the disc using the instructions in the following section. Then, refer back to Step 3 and examine the disc orientation in the caddy.

3.3 Unloading a Disc

Before unloading a disc, make sure that the **ACTIVITY** indicator is not flashing. If it is flashing, then the RRD40 is transferring data. Wait until the indicator stops flashing.

The unloading procedure is a reverse of the loading procedure. Use Figure 3-2 as a guide.

1. Orient the transparent sleeve for loading. Make sure the arrow on the sleeve is pointing towards the drive.
2. Insert the sleeve into the disc opening on the front of the drive as far as it will go.
3. Remove the caddy. The disc and housing will be back in the sleeve. The **ACTIVITY** indicator will go out.

3-4 Operation

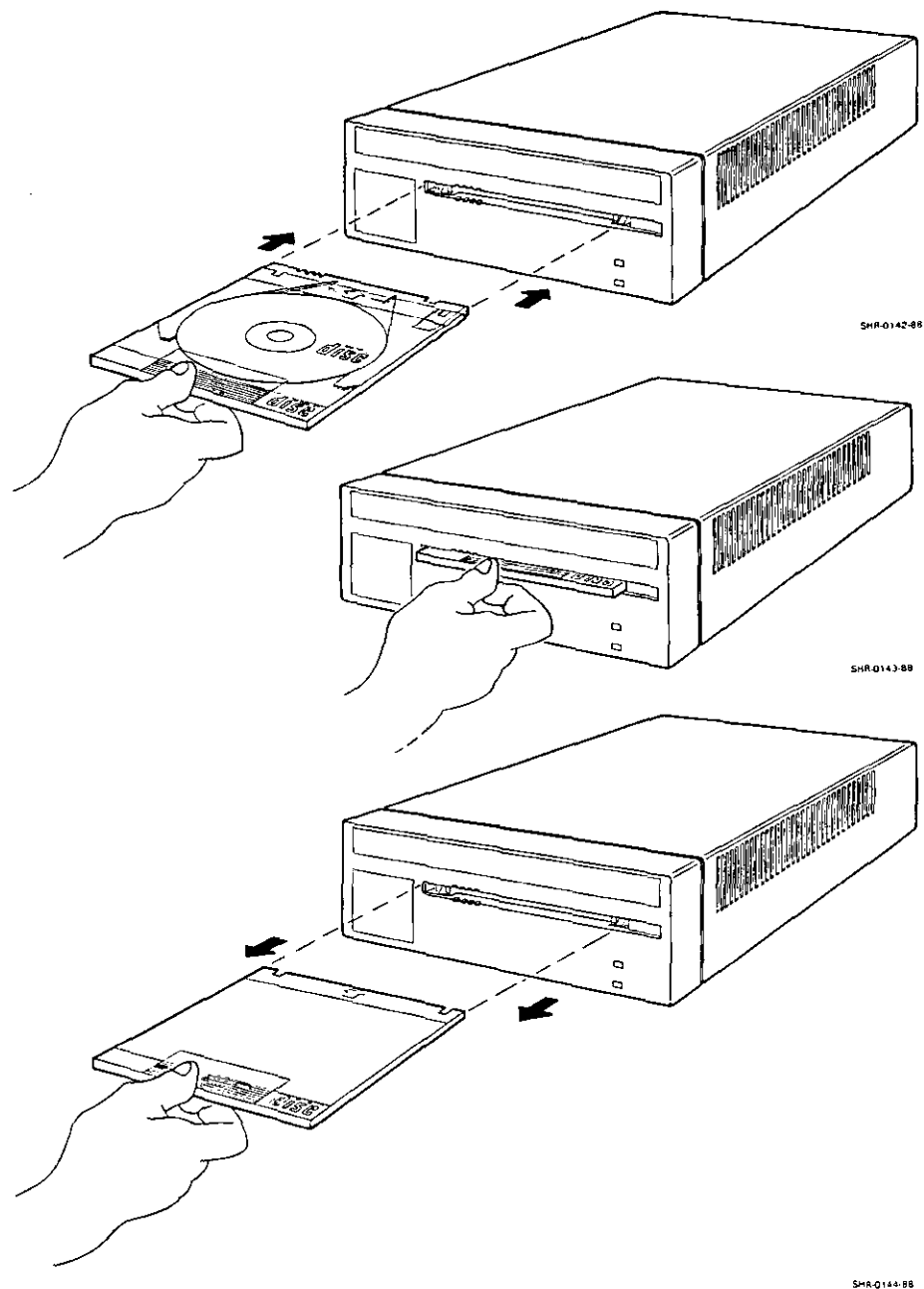

Figure 3-2 Disc Loading

3.4 Disc and Caddy Repairing

The RRD40 media is contained inside a protective caddy. The caddy consists of three parts: the disc, the disc housing, and the transparent sleeve (see Figure 3-3).

If the transparent sleeve is damaged or cracked or if the disc needs cleaning, the caddy can be taken apart and replaced if necessary.

It is important that the disc is mounted in the caddy correctly. Failure to mount the disc correctly will make the disc inaccessible by the host computer.

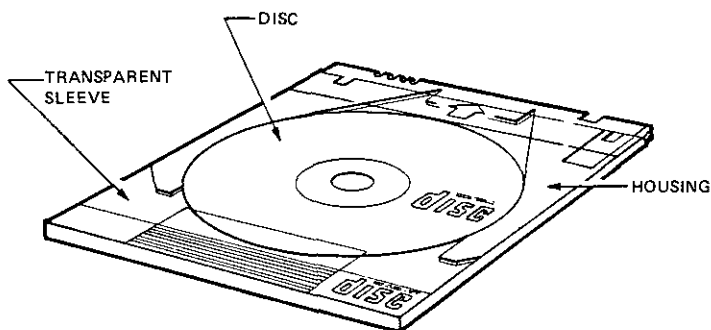

SHR-0140-BB

Figure 3-3 Caddy Parts

3.4.1 Removing the Disc from the Caddy

To remove the disc from the caddy for cleaning or caddy repairing, proceed as follows:

1. Hold the caddy so that the label on the disc is facing down. Locate the locking tabs on either side of the disc housing, as shown in Figure 3-4.

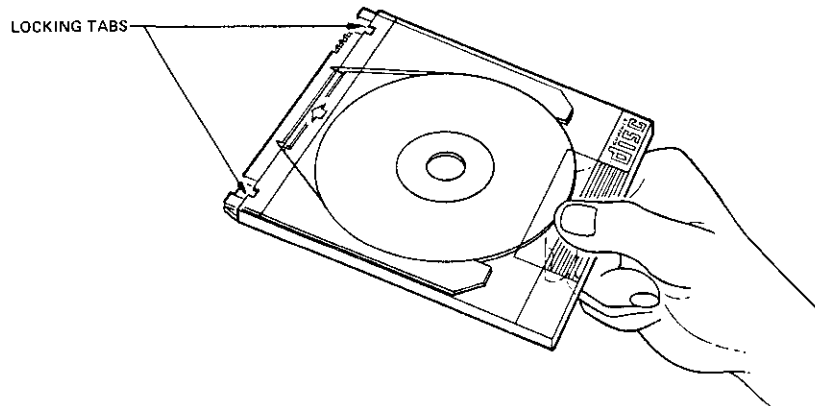

SHR-0145-88

Figure 3-4 Disc Tabs

2. For each locking tab, press down on the tab while slightly separating the housing from the sleeve. Use your fingernail or a pointed instrument.

When both tabs have been disengaged, pull the disc housing out to about the midpoint of the disc (Figure 3-5).

3. Hold the disc housing on each side as shown in Figure 3-5. Exert slight inward pressure on the housing so the disc will not fall out. Remove the sleeve from the housing. Place the sleeve aside.

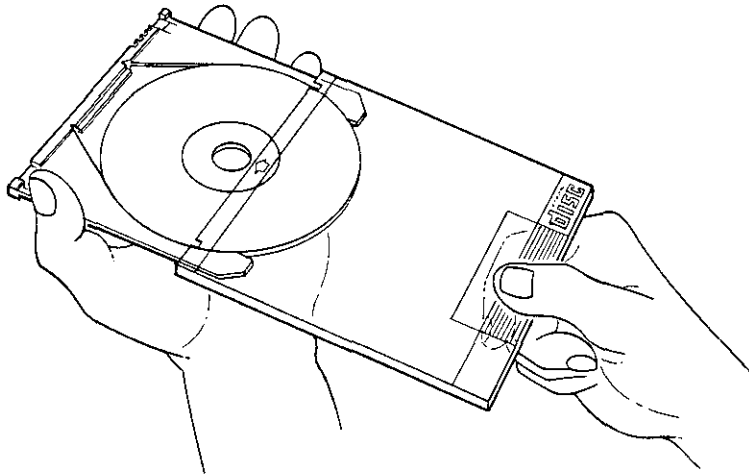

SHR-0146-88

Figure 3-5 Separating the Caddy

3-8 Operation

4. Grasp the disc with your free hand as shown in Figure 3-6. Position your thumb on the outer edge of the disc and your index finger in the center hole of the disc. Release pressure from the housing and remove the disc.

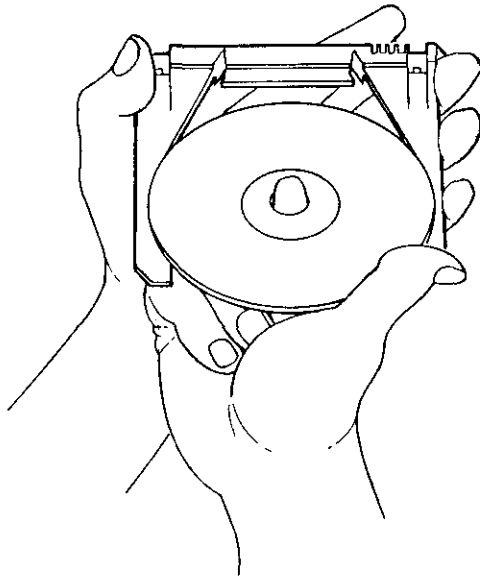

SHR-0147-88

Figure 3-6 Separating the Disc and Housing

3.4.2 Cleaning a Disc

The disc can be cleaned with a dry, lint-free cloth. The disc should always be free of dust, dirt, and fingerprints. Always hold a disc by the edges. Never touch the data area of the disc.

To clean, always wipe from the center of the disc to the edges. Use small circular strokes. Do not use a continuous circular stroke around the disc.

3.4.3 Replacing the Disc in the Caddy

Assembling the caddy is essentially a reverse of the procedures given in Section 3.4.1. Make sure that your hands are positioned as shown in the illustrations. It is important that you replace the disc correctly.

1. Position the housing and disc **EXACTLY** as shown in Figure 3-6. (Make sure the label on the disc is facing **DOWN**.)
2. Insert the disc into the housing. The inside of the housing is grooved to accept the disc. Exert slight inward pressure to hold the disc in the housing.
3. With your free hand, get the transparent sleeve. Notice that the sleeve is symmetrical. Slide the housing all the way into the transparent sleeve until it clicks into place.
4. Turn the assembled caddy over so that the label on the disc is facing up. Examine the housing. When the caddy is loaded into a drive, the notches on the caddy are in the upper left hand corner. These notches line up with the notches on the drive (Figure 3-1).

If the notches are not on the left side when the caddy is positioned for loading (label side of the disc up), then the disc is mounted inside the caddy incorrectly! Remove the disc from the caddy and orient it properly.

It is extremely important that the disc is mounted inside the caddy correctly. The RRD40 drive cannot access data from a disc that is mounted incorrectly!

Testing the RRD40 on a MicroVAX

This chapter gives instructions on how to test the RRD40 Subsystem through the MicroVAX Diagnostic Monitor (MDM). These tests work only on MicroVAX host systems (Q-Bus interface). The RRD40 with the SCSI interface is tested through the host system. The procedures for testing all SCSI devices apply to the RRD40. Refer to the testing sections in the host system documentation.

4.1 Running Tests on MicroVAX Host Systems

Testing on the MicroVAX is done through the MicroVAX Diagnostic Monitor (MDM). The monitor is used by service personnel as well as MicroVAX customers. This chapter gives a brief outline of MDM as it applies to customers and service personnel. However, if you need more information about MDM, please consult Digital's *MicroVAX Diagnostic Monitor User Guide* (part number AA-FM7AA) which contains details on running all modes of MDM.

To run RRD40 tests on the MicroVAX, you need the MicroVAX Diagnostic Monitor (MDM) Diagnostic Kit. Use the floppy that contains the RRD40 diagnostics from the kit. Unless you have purchased a MicroVAX Maintenance Kit, you will be limited in the diagnostics you will be able to run. The MicroVAX Maintenance Kit contains the necessary license that allows you to run extensive system tests.

For more information on purchasing the MicroVAX Maintenance Kit, contact your Digital Service Representative.

4.2 Customer Run Tests on a MicroVAX Host System

This section gives instructions for running Verify Mode tests through the MicroVAX Diagnostic Monitor (MDM). This mode of testing is completely menu driven. For service mode testing, go to Section 4.3.

4.2.1 Equipment

Before running the MicroVAX Diagnostic Monitor, insert the test disc into the RRD40 drive that you are testing. Some of the tests need the test disc to run.

4.2.2 Running MDM: Customer Mode

Running diagnostics for the RRD40 is essentially the same as running any other diagnostics. When MDM is loaded, the following appears on the screen:

```
MicroVAX Maintenance System      MDM Version V2.21

CONFIDENTIAL DIAGNOSTIC SOFTWARE
PROPERTY OF
DIGITAL EQUIPMENT CORPORATION

Use Authorized Only Pursuant to a Valid Right-to-use License

Copyright (c) 1986, 1987
Digital Equipment Corporation

Current date and time is: 01-OCT-1988 10:35:25.33

Press the RETURN key to continue,
OR enter the new date and time, then press the RETURN key.

[DD-MMM-YYY HH:MM]:
```

Enter the date and time here (if necessary) and press RETURN. The screen then gives the date and time that you just entered, and displays the MicroVAX Diagnostic Monitor Main Menu.

```
MAIN MENU                                     Version V2.21

  1  Test the system
  2  Show system configuration and devices
  3  Display the System Utilities menu
  4  Display the Service menu
  5  Exit MicroVAX Maintenance System

Type the number; then press the RETURN key. >
```

- **Option 1** will execute the functional test set on the RRD40 drive. The functional test set is listed in Table 4-1.
- **Option 2** will display all the devices on the system. This list should include the RRD40 you want to test.
- **Option 3** will display a menu to run various system utilities. For the RRD40, the utilities are used by Field Service Personnel only (with the one exception mentioned below) and are not for use by customers. The Utility tests for the RRD40 are listed in Table 4-3.

The customer may select this option to set the RRD40 drive unit number. This is the only utility that can be run by non-service personnel.
- **Option 4** will display a menu to run service mode tests on the RRD40. This menu will not be displayed unless you have purchased the MicroVAX Maintenance Kit. The Service Mode tests are listed in Table 4-2.
- **Option 5** exits you from MDM.

Select Option #2 and make sure that the RRD40 is listed as a device on the system. When this is verified, return to the Main Menu and select Option #1 to run the Verify Mode Functional Tests (refer to Table 4-1).

4-4 Testing the RRD40 on a MicroVAX

When you select Option #1, the following appears on the screen:

```
MAIN MENU                                     Version V2.21
SYSTEM TEST

This is a test of the MicroVAX computer and its devices.

No additional preparation for this testing is required;
the MicroVAX is ready to be tested.

Testing occurs in two parts; the functional tests quickly
test each device sequentially; the exerciser test (lasting
about 4 minutes) tests how the devices work together.

To halt the test at any time and return to the Main Menu
type CTRL-C by holding down the CTRL key and pressing the C key.

Press the RETURN key to begin testing,
or type 0 and press the RETURN key to return to the Main Menu. >
```

The entire test set takes about 7-8 minutes. After the testing session ends, a message will appear on the screen informing you of the successful (or unsuccessful) completion of the tests.

If a failure occurred, an error message will print out. This error report is for use by specially trained Digital Field Service Engineers. Refer to Section 4.3.6.

Table 4-1 Verify Mode Functional Tests

Test Number	Test Name	Test Duration (seconds)
1	Register Existence Test	> 1
2	Level 1 Power Up Microdiagnostics	> 2
3	Initialization Steps 1—4	> 1
4	Diagnostic Wrap Mode Test	> 1
5	Vector and BR Level Test	> 1
6	Purge and Poll Test	> 2
7	Small Ring Buffer Initialization Test	> 1
8	Large Ring Buffer Initialization Test	> 10
9	Get Dust Status Test	> 5
10	Server Functionality Verification	> 10
11	RRD50/RRD40 Drive Microdiagnostic Test	> 15 per tested drive
12	RRD50/RRD40 Drive Spinup/Spindown Test	50 per tested drive
13	RRD50/RRD40 Drive Data Transfer Rate Test	20 per tested drive
14	RRD50/RRD40 Drive Access Time Test	20 per tested drive
15	RRD50/RRD40 Drive Basic Read Data Test	20 per tested drive
16	RRD50/RRD40 Drive Worse Case Read Data Test	20 per tested drive
17	RRD50/RRD40 Drive Forced Errors Test	20 per tested drive

Table 4-2 Service Mode Functional Tests

Test Number	Test Name	Test Duration (seconds)
1—17	Same as verify tests	
18	Basic Seek and Read Data Tests	30 per tested drive
19	Seek Position Test	30 per tested drive
20	Short Data Reliability Test	35 per tested drive
21	Spinup/Spindown Data Reliability Test	50 per tested drive

Table 4-3 Utilities

Test Number	Test Name	Test Duration
1	Enable RRD50/RRD40 Firmware Error Logs	1 second
2	Update Controller Hardware Revision Level	20 seconds
3	Force Diagnostic Statistical Report	40 seconds
4	Extended Data Transfer Rate Test	25 minutes
5	Extended Data Reliability Test	2 hours, 30 minutes
6	Auto Spin Down Test	25 minutes
7	Update RRD40 Drive Unit Number	1 minute

4.3 Service Mode Testing on a MicroVAX Host System

This section gives instructions for service personnel (and customers who have purchased the MicroVAX Maintenance Kit) to run tests through the MDM. This mode of testing can be either menu driven or driven in command line mode. For customer testing, refer back to Section 4.2.

4.3.1 Equipment

Before running the MicroVAX Diagnostic Monitor, insert the test disc into the RRD40 drive that you are testing. Some of the tests need the test disc to run.

4.3.2 Running MDM: Menu/Command Line Mode

Running diagnostics for the RRD40 is essentially the same as running any other diagnostics. When MDM is loaded, the following appears on the screen:

```
MicroVAX Maintenance System      MDM Version V2.21

CONFIDENTIAL DIAGNOSTIC SOFTWARE
PROPERTY OF
DIGITAL EQUIPMENT CORPORATION

Use Authorized Only Pursuant to a Valid Right-to-use License

Copyright (c) 1986, 1987
Digital Equipment Corporation

Current date and time is: 01-OCT-1988 10:35:25.33

Press the RETURN key to continue,
OR enter the new date and time, then press the RETURN key.

[DD-MMM-YYY HH:MM]:
```

4-8 Testing the RRD40 on a MicroVAX

Enter the date and time here (if necessary) and press RETURN. The screen then gives the date and time that you just entered, and displays the following:

```
Do you want to use menu mode or command line mode?
```

- 1 - menu mode
- 2 - command line mode

```
Type the number; then press the RETURN key
```

Menu Mode

If you want menu mode, press the 1 key and then press RETURN. You will enter menu mode and the Main Menu will appear on the screen. Refer to Section 4.2.

Command Line Mode

If you want command line mode, press the 2 key and then press RETURN. The following will appear on the screen:

```
CAUTION: You are about to enter command line mode.  
There are no menus once you enter this mode. Refer  
to the MDM User's Guide for detailed instructions.
```

```
To return to the menu mode from command line mode,  
type "RESTART" and press the RETURN key, or reboot  
the system.
```

```
Type 2 and press the RETURN key to proceed, or  
type 1 and press the RETURN key to enter menu mode. >
```

If you want command line mode, press the 2 key and then press RETURN. You will enter command line mode and the MDM >> prompt will appear on the screen.

The MDM >> prompt signifies that you are in command line mode of the MicroVAX Diagnostic Monitor.

4.3.3 Help

The Help function gives a brief outline of all testing commands. Just type HELP at the MDM >> prompt and a command summary is displayed on the screen.

SET/SHOW

The Set and Show commands set up and display the testing mode and the specific tests to run. The Set command has many qualifiers that you can use. Table 4-4 lists the various Set and Show commands. The commands are listed by groups in the first column. Table 4-4 also lists what to type in (to set a specific testing parameter) and what each command does.

Each group has a default parameter. The default is what is set if no specific Set command is given. The default is always the first option given in the *What to Type In* field of the table.

START

After the system is configured and the testing parameters are set up, type *START* at the MDM >> prompt to run the selected tests.

SAMPLE TEST SETUP AND RESULTS

The following is an example of what the screen looks like when running customer tests. Comments are included in parentheses.

```
MDM >> CONFIGURE           (Configures system)
MDM >> SELECT RRDXXA       (Selects the RRD40 diagnostics
                           from MDM; one controller is
                           being tested)

MDM >> SET MODE VERIFY     (Sets mode to VERIFY)
MDM >> SET PROGRESS FULL   (Screen will display progress
                           report)

MDM >> SET SECTION FUNCTIONAL (Sets FUNCTIONAL tests)
MDM >> SET TEST 1,3       (Run tests 1 and 3)
MDM >> SET PASSES 2       (Run each test 2 times)
MDM >> START              (Begin)
MDM >>
MDM >> RRD40A started by MDM
RRD40A DSL Pass Number 1   Test number 1
RRD40A DSL Pass Number 2   Test number 1
RRD40A DSL Pass Number 1   Test number 3
RRD40A DSL Pass Number 2   Test number 3
MDM >>
```

4.3.4 Tests

There are three types of tests: Functional, Utility, and Exerciser. There are two modes of testing: Verify and Service.

Table 4-1 and Table 4-2 list all the functional tests that can be run in each mode.

Table 4-3 lists all the utilities. Utilities can only be run in service mode.

The Exerciser tests are used to test the entire system, not just the RRD40. There is one exerciser test in verify mode and two exerciser tests in service mode.

4.3.5 Running the Tests

The specific commands to run tests (some or all) are as follows:

- **Configure**—Sets up the system for its specific configuration
- **Select**—To choose a group of diagnostics on the MDM floppy
- **Set**—To set up parameters for testing
- **Start**—To run the selected tests

CONFIGURE/SELECT

The first steps in running diagnostics are the Configure and Select commands. Type Configure at the MDM >> prompt and press the RETURN key. When the configure is done, another MDM >> prompt appears. At that prompt, type SELECT RRDXXA. This selects the group of RRD40 diagnostics from the floppy, and specifies that only one controller is to be tested. If you have two RRD40 controllers on the system and you want to test both controllers, type SELECT RRDXXA,RRDXXB.

NOTE: Do not confuse controllers with drives. If you have two RRD40 drives on one controller, you still type SELECT RRDXXA.

When the RRD40 diagnostics are selected, the screen displays the MDM >> prompt.

The next step is to SET the parameters for testing.

Table 4-4 (Cont.) Diagnostic Monitor: Set/Show Commands

Command Group	What to Type In	What the Command Does
	SET SECTION UTILITY	This section has two different tests that can be set. Utility Test 1 enables the RRD50/RRD40 firmware error logs. Utility Test 2 is for updating the serial RAM in the event that a new revision level of the controller is installed.
	SET SECTION EXERCISER	This command selects the exerciser tests. In verify mode, there is one exerciser test. In service mode, there are two exerciser tests. These tests exercise the RRD40 as well as other storage devices on the system.
NUMBER	SET TEST ALL	This command runs all tests in the mode and section selected. (Verify mode runs tests 1—17; Service mode runs tests 1—21.)
	SET TEST number	This command runs a specific test or a specific series of tests. (Examples: SET TEST 2: runs test 2. SET TEST 2-4: runs tests 2, 3, and 4. SET TEST 2,4-6,8: runs tests 2, 4, 5, 6, and 8.)
TIMES TO RUN	SET PASSES number	This command runs tests the number of times specified in this command: Example: the command SET PASSES 10 runs each test that is Set to run 10 times.
STATUS	SHOW CONFIGURATION	This command shows the number of RRD50/RRD40 controllers being tested.
	SHOW DEFAULT	This command shows the current selected testing parameters.

Table 4-4 Diagnostic Monitor: Set/Show Commands

Command Group	What to Type In	What the Command Does
MESSAGE	SET DETAILED MESSAGE OFF	This command gives a brief message if a test fails (in either mode).
	SET DETAILED MESSAGE ON	This command causes a detailed error report to display on the screen in the event that a test fails. The error report is for use by Field Service and should not be run by customers.
PROGRESS	SET PROGRESS OFF	This command does NOT give a progress report on the screen.
	SET PROGRESS BRIEF	This command gives a screen message for successful completion of a test (full number of passes). For example, if you run test number 5 ten times, the screen displays a message after the tenth pass of the test.
	SET PROGRESS FULL	This command gives a screen message for each run ("pass") of each test (regardless of whether the test passes or fails). If a test fails, a detailed error report is given.
MODE	SET MODE VERIFY	This command selects Verify mode (Customer tests 1-17. See Table 4-1 for test names). These tests take two to three minutes (per drive) to run.
	SET MODE SERVICE	This command selects Service mode (Tests 1-21, for use by Field Service. See Table 4-2 for test names). These tests take three to four hours (per drive) to run.
SECTION	SET SECTION FUNCTIONAL	This command selects the functional tests (Verify mode runs Tests 1-17; Service mode runs Tests 1-21).

Table 4-5 Drive Error Codes (Service Mode Only)

CODE	MEANING
00	No error
02	Illegal sector address
03	Sync error
04	Seek error (the requested sector could not be found)
05	Track error
06	End of disk
08	Focus error
09	Illegal disk
0B	ROM error
0C	RAM error
0D	Disc not readable
0E	Hard reset complete
0F	Operator requested spin down
10	Selected disk not present (Jukebox only)
13	Unit number changed
14	Radial error
15	Spin down due to inactivity timeout
16	Operator requested spin up
18	Subcode error
19	Illegal stop address
1A	Stop address out of track
1B	Track not on disc
1C	Command not according to track
1D	Wrong scan result
1E	Disc cover in drive

4.3.6 Error Reports

If a test fails, an error message displays.

EXAMPLE: During verify mode testing (with DETAILED MESSAGE OFF), the RRD40 Drive Microdiagnostics Test (Test 11) failed. The following appears on the screen:

```
RRDXXA -- Error Number 1103
RRD50/RRD40 DRIVE FAILED MICRODIAGNOSTIC TEST
RRD50/RRD40 CABLE/DRIVE A
```

The four-digit error number (code) that is given on the screen has the following format.

TTSS:

where TT is the test number (defined in Table 4-1 and Table 4-2), and SS is the section of the test that failed.

In the previous example, the error number is 1103. This means that Test 11 (Microdiagnostic Test), Section 3, failed.

DETAILED ERROR REPORT

When SET DETAILED MESSAGE ON is set in service mode, a detailed error report displays if a test fails. This error report is for use by specially trained technicians and field engineers.

If two disc drives exist on one controller, this report also defines which one of the two drives on that controller failed. The report identifies the two drives by port number. Port A is the drive attached to the A connector on the connector panel. Port B is the drive attached to the B connector on the connector panel.

The detailed error report defines the failed test, giving specific error codes for the disc drive or controller, whichever applies. Drive error codes are listed in Table 4-5. Controller error codes are listed in Table 4-6.

WHAT TO DO WHEN A TEST FAILS

When a test fails, always try again. If the test fails twice, contact your Digital service representative. Your service representative will instruct you on what to do.

Remember that you cannot replace the controller or any of its associated cables on Q-Bus host systems. You may void your service contract by opening up your host system. If you have questions on your contract limitations, call your Digital service representative or call 1-800-DIGITAL.

Table 4-6 (Cont.) Controller Error Codes (Service Mode Only)

CODE	MEANING
70	Auto spin down function did not work
80	Illegal command test failed
83	Spin up bit not set
84	Spin down bit not set
93	Soft read error, miscompare error, and data error
94	Hard read error, miscompare error, and data error
96	EDC error; ECC failed and EDC failed (Error 31, 32, and 33)
97	Soft read error, miscompare error, and EDC error
98	Hard read error, miscompare error, and EDC error
A6	Soft read error, miscompare error, data error, and EDC error
A7	Hard read error, miscompare error, data error, and EDC error

Table 4-6 Controller Error Codes (Service Mode Only)

CODE	MEANING
01	Controller indicated request could not be performed
02	Controller indicated host access error
03	Controller indicated sequence error
04	No disc in drive, or disc in upside down
05	No drive
06	Controller error
07	Small disc error
08	No free request packet controller error
09	Drive has a fatal error
10	Abort set in request packet
20	Maximum access time is too high
21	Minimum access time is too high
31	Data error
33	EDC failed
40	Miscompare error
41	Misposition error
42	Soft read error
43	Hard read error
50	Data transfer rate failed
51	Miscompare error and data error
53	Soft read error and data error
54	Hard read error and data error
55	Miscompare error and EDC error
56	Soft read error and EDC error
57	Hard read error and EDC error
64	Miscompare error, data error, and EDC error
66	Soft read error, data error, and EDC error
67	Hard read error, data error, and EDC error

Digital Repair Services

Digital Field Service offers a range of flexible service plans.

On-Site Service offers the convenience of service at your site and insurance against unplanned repair bills. For a small monthly fee, you receive personal service from our service specialists. Within a few hours, a specialist is dispatched to your site with equipment and parts to give you fast and dependable maintenance.

Basic Service offers full coverage from 8 a.m. to 5 p.m., Monday through Friday. Options are available to extend your coverage to 12-, 16-, or 24-hour days, and to Saturdays, Sundays, and holidays.

DECservice offers a premium, on-site service providing committed response to remedial service requests made during contracted hours of coverage. Remedial maintenance will be performed continuously until the problem is resolved, which makes this service ideal for customers requiring maximum service performance.

Under Basic Service and DECservice, all parts, materials, and labor are covered in full.

Carry-In Service offers fast, personalized response, and the ability to plan your maintenance costs for a smaller monthly fee than On-Site Service. When you bring your unit to one of 160 Digital Servicers worldwide, factory-trained personnel repair your unit within two days. This service is available on selected terminals and systems. Contact your local Digital Field Service office to see if this service is available for your unit.

Digital Servicers are open during normal business hours, Monday through Friday.

DECmailer offers expert repair at a per use charge. This service is for users who have the technical resources to troubleshoot, identify, and isolate the module causing the problem. Mail the faulty module to our Customer Returns Center where the module will be repaired and mailed back to you within five days.

A-2 Digital Repair Services

Per Call Service offers a maintenance program on a noncontractual, time-and-materials-cost basis. This service is available with either On-Site or Carry-In Service. It is appropriate for customers who have the expertise to perform first-line maintenance, but may occasionally need in-depth support from Field Service.

Per Call Service is also offered as a supplementary program for Basic Service customers who need maintenance beyond their contracted coverage hours. There is no materials charge in this case.

On-Site Per Call Service is provided on a best effort basis, with a normal response time of two to three days. It is available 24 hours a day, seven days a week.

Carry-In Per Call Service is available during normal business hours, with a two to three day turnaround.

For more information on these Digital service plans, prices, and special rates for volume customers, call the Digital Field Service office nearest you.